



Becker & Hickl GmbH

Nahmitzer Damm 30
12277 Berlin

Fon +49 (30) 787 56 32
Fax +49 (30) 787 57 34

Email info@becker-hickl.com

TCSPC Performance of the id100-50 Detector

This report summarizes the results of Becker&Hickl's evaluation of the id100-50, a single photon counting module manufactured by id Quantique (www.idquantique.com).

Detector

The id100-50 of id Quantique is an actively quenched single-photon APD (SPAD) module. The quenching circuit is integrated on the diode chip. Compared with the id100-20, the id100-50 has a 6.25 time larger active area. The larger area simplifies optical alignment and focusing while maintaining the low dark count rate and the good time resolution of the id100-20. The key parameters are:

Spectral range	350 to 900 nm
Diameter of the active area	50 μm
Timing resolution (fwhm)	55 ps
Detection probability at 500 nm	35 %
Dark count rate	$< 200 \text{ s}^{-1}$
Output pulse amplitude	+ 2 V

Test Setup

The id100-50 was tested in the setup shown below.

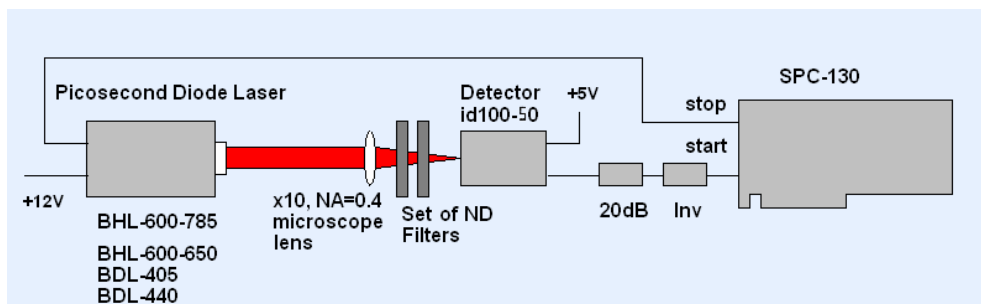

Light pulses of a picosecond diode laser were attenuated by a package of neutral density (ND) filters and focused directly to the SPAD module. The output pulses of the detector were sent to the start input of a TCSPC module. To transform the pulse polarity and the pulse amplitude into the standard

input range of the TCSPC module a 20 dB attenuator and a passive pulse inverter were inserted in the signal line. The timing reference pulses at the stop input of the TCSPC module came directly from the laser.

For the measurement of the TCSPC instrument response function we used a BHL-600-785 diode laser. This laser has an exceptionally short pulse width of the order of 24 ps. For the measurement of the diffusion tail at various wavelengths a BHL-600-650 (650 nm), a BDL-440-SM (444 nm), and a BDL-405-SM (405 nm) were used. The measurements of the instrument response functions (IRFs) were performed by an SPC-130 TCSPC module. All lasers and TCSPC modules are Beckel&Hickl products.

Instrument Response Functions (IRFs)

IRF recordings measured at a wavelength of 785 nm are shown in fig. 2. The curves were measured at detector count rates from 214 kHz to 8.1 MHz. The maximum ADC resolution and TAC gain of the SPC-130 was used, resulting in a time channel width of 813 fs.

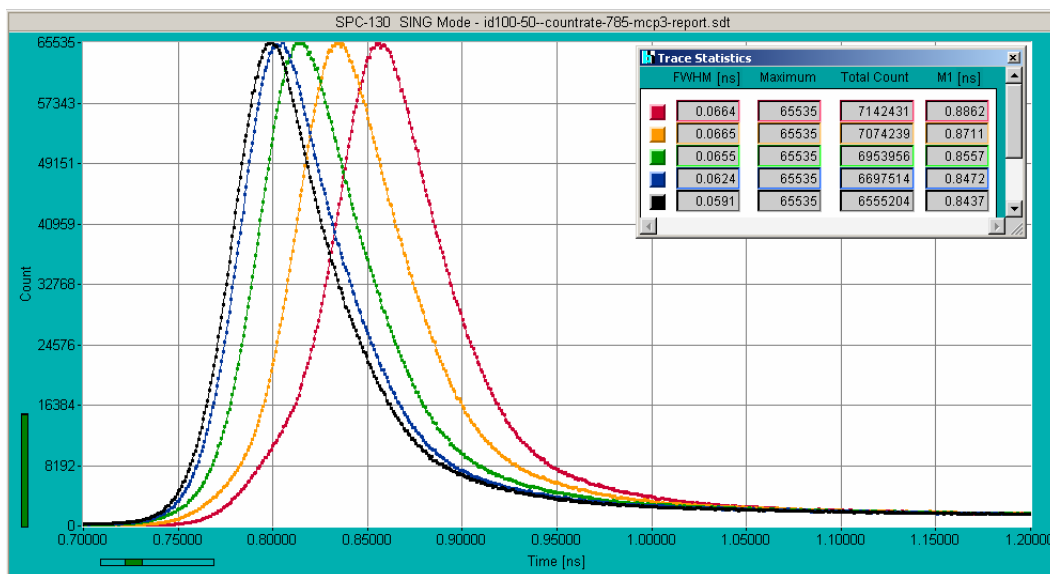

Fig. 2: IRF of the id100-50 at 785 nm. Detector count rates 8.1 MHz (red), 5.15 MHz (yellow), 2.1 MHz (green), 0.5 MHz (blue) and 62 kHz (black). Time scale 50 ps per division. The FWHM and the first moment of the IRF curves are shown in the insert.

The measured width of the IRF (Instrument Response Function) varies from 66 ps to 59 ps. Corrected with an estimated width of the laser pulse of 24 ps, these values correspond to 55 ps to 61 ps, in agreement with the id Quantique specifications.

To quantify the shift of the IRF with the count rate, the first moments, M1, of the IRF curves were calculated. The shift of the first moment is

Count Rate (MHz)	0.2	0.5	2.1	5.15	8.1
Shift of M1 (ps)	0	3.5	12	28	42

Compared to other APD modules, these values are exceptionally low. It should also be noted that the IRFs remain free of satellite pulses or other artefacts up to the highest count rates applicable with currently available TCSPC techniques.

The IRFs of all single-photon APDs have a ‘diffusion tail’ caused by carrier generation in the neutral layers below the avalanche region. The amplitude of the tail depends on the wavelength and

can reach 10 to 20% of the IRF peak. The diffusion tail of the id-100-50 for different wavelengths is shown in fig. 3.

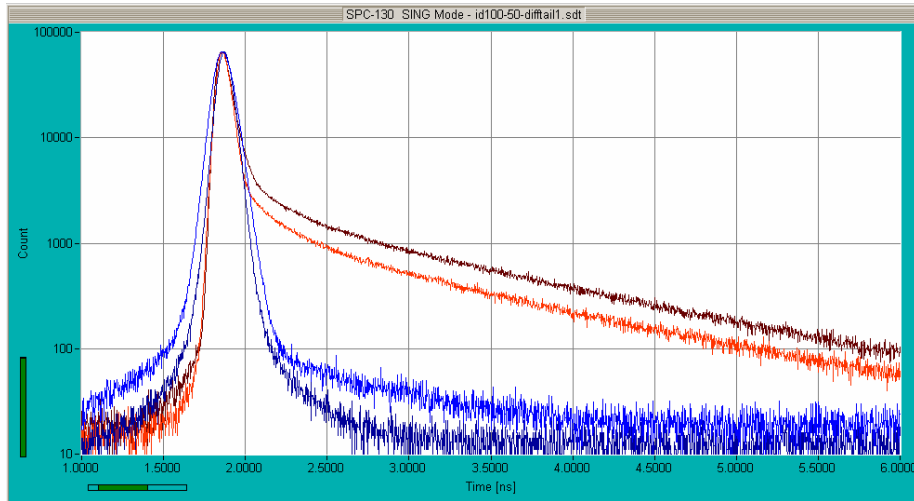

Fig. 3: Diffusion tail in the IRF of the id-100-50. 785nm (dark red), 650 nm (red), 444 nm (light blue), 405 nm (dark blue). The amplitude of the tail is about 5% and 3% at 650 and 785 nm. At 444 nm the tail is at the limit of detection, at 405 nm it is not detectable.

With 5% and 3% at 785 nm and 650 nm, respectively, the amplitude of the tail is relatively low. At 444 nm and 405 nm the diffusion tail is almost not detectable.

Afterpulsing

The afterpulsing of the id100-50 was checked by recording a continuous light signal in the time-tag (FIFO) mode of the TCSPC module. The time-tag data were used to record the autocorrelation function of the photon times. Consequently, the curve resembles the result of a fluorescence correlation (FCS) measurement. The result is shown in fig. 4. The autocorrelation function is normalised to the correlation expected for uncorrelated photon data, i.e. a correlation factor of 1 means that there is no correlation between the events.

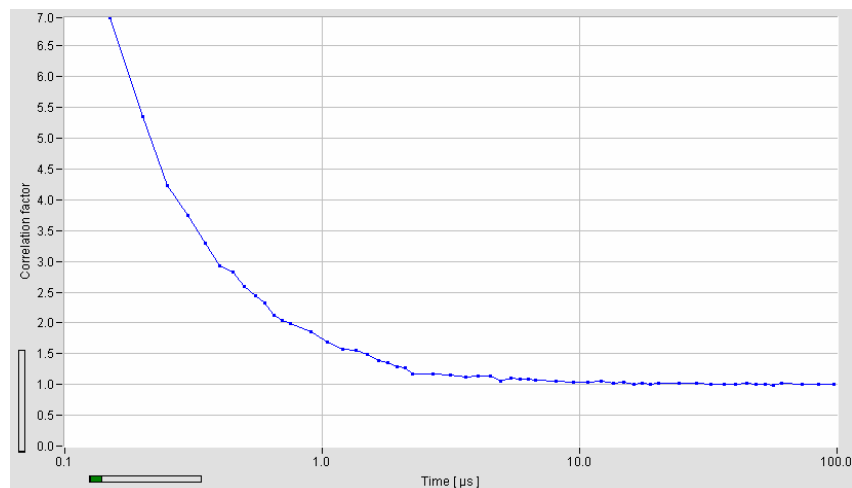

Fig. 4: Autocorrelation function of a light signal of constant intensity, recorded at a count rate of 10 kHz.

When comparing the autocorrelation curves of different detectors, please take into regard that the absolute amplitude of the autocorrelation curve is proportional to the reciprocal count rate.

Quantum Efficiency

We attempted to compare the quantum efficiency of the id100-50 with the quantum efficiency of a Hamamatsu H5773-20 PMT module. The H5773-20 has a 'high efficiency extended red' photocathode featuring exceptionally high quantum efficiency in the red and NIR range of the spectrum. At 650 nm, the efficiency of both the id100-20 and the id100-50 detectors were found about 3 times higher than for the PMT module. Based on the spectral sensitivity given for the H5773-20 the quantum efficiency of the id-100 can be estimated to be 25 to 40% at 650 nm. These values are similar or even better than the 'detection probability' (22% at 650 nm) specified for the id100-50 and -20.

Conclusions

The id100-50 of id Quantique has an extremely fast IRF and an excellent timing stability up to detector count rates of at least 8 MHz. The IRF is free of bumps and pre-pulses, and drops smoothly at longer times. The timing performance comes close to that of the smaller id100-20 module. The id100-50 is a wonderful detector for all applications in which the light can be concentrated on a small detector area. The good timing stability at high count rates then makes the id100-20 a real alternative to the R3809 MCP PMTs commonly used in TCSPC experiments. Potential applications are single-molecule spectroscopy, time-resolved confocal microscopy, and experiments of quantum-key distribution. Moreover, the detector is particularly suitable for a large number of applications at relatively high light intensity.

Wolfgang Becker
Becker & Hickl GmbH
Nahmitzer Damm 30
12277 Berlin
Tel. +49-30-787 56 32
Fax +49-30-787 57 34
becker@becker-hickl.com
<http://www.becker-hickl.com>



Performance of the id100-20 Detector in B&H TCSPC Systems

This report summarizes the results of Becker&Hickl's evaluation of the id100-20, a single photon counting module manufactured by id Quantique (www.idquantique.com)

Detector

The id100-20 of id Quantique is an actively quenched single-photon APD (SPAD) module. The quenching circuit is integrated on the diode chip. The key parameters are (typical values):

Spectral range	350 to 900 nm
Diameter of the active area	20 μm
Timing resolution (fwhm)	40 ps
Detection probability at 500 nm	35 %
Dark count rate	200 s^{-1}
Output pulse amplitude	+ 2 V

Test Setup

The id100-20 was tested in the setup shown below.

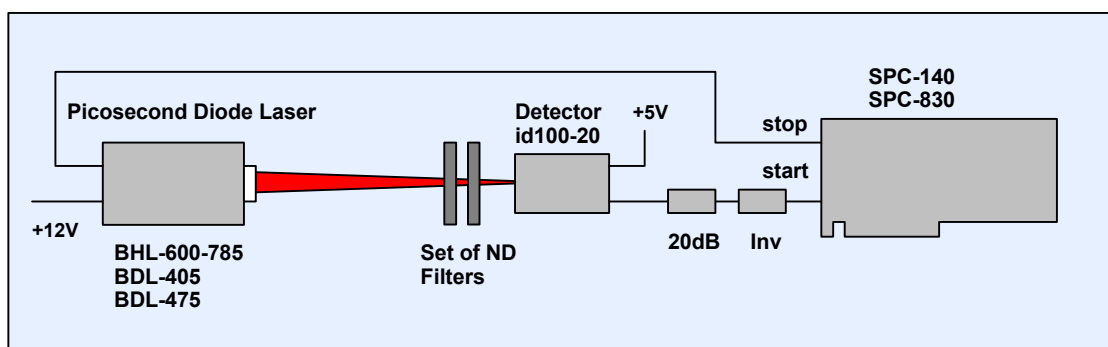

Light pulses of a picosecond diode laser were attenuated by a package of neutral density (ND) filters and sent directly to the SPAD module. The output pulses of the detector are sent to the start input of a TCSPC module. To transform the pulse polarity and the pulse amplitude into the standard input range of the TCSPC module a 20 dB attenuator and a passive pulse inverter were inserted in the signal line. The timing reference pulses at the stop input of the TCSPC module come directly from the laser.

For measurements at various wavelengths we used three different lasers. A BHL-600-785 was used at 785 nm. This laser has an exceptionally short pulse width of the order of 24 ps. The BDL-405 and the BDL-475 were used at 405 nm and 468 nm. The pulse width was about 68 ps and 58 ps, respectively. The measurements of the instrument response functions were performed by an SPC-140 TCSPC module, the correlation measurement by an SPC-830 module. All lasers and TCSPC modules are Beckel&Hickl products.

Instrument Response Functions (IRFs)

Instrument response functions measured at 785 nm are shown in fig. 2. The response was measured at a count rate of 5 MHz, 2.7 MHz, and 62 kHz.

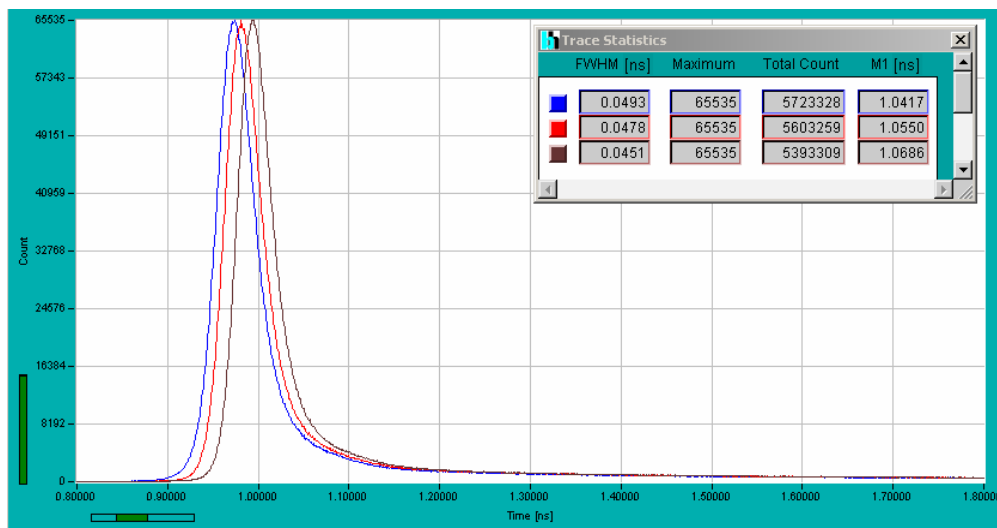

Fig. 2: IRF at 785 nm. Count rates 5 MHz (blue), 2.7 MHz (red), and 62 kHz (black). Time scale 100 ps per division. The FWHM and the first moment of the IRF curves are shown in the insert.

The measured width of the IRF (Instrument Response Function) varies from 49 ps to 45 ps. Corrected with an estimated width of the laser pulse of 24 ps, these values correspond to 43 ps to 38 ps, in agreement with id Quantique specifications.

To quantify the shift of the IRF with the count rate, the first moments, M1, of the IRF curves were calculated. The shift between 5 MHz and 2.7 MHz and 63 kHz is 13 ps and 26.9 ps. Compared to other APD modules, these values are exceptionally low. They are in fact smaller than for a XP2020 PMT with a standard voltage divider.

Fig. 3 compares the IRF of the id100-20 with the IRF of an R3809U-50 MCP-PMT operated at -3 kV. The measured FWHMs are 47 ps for the SPAD and 37 ps for the MCP-PMT.

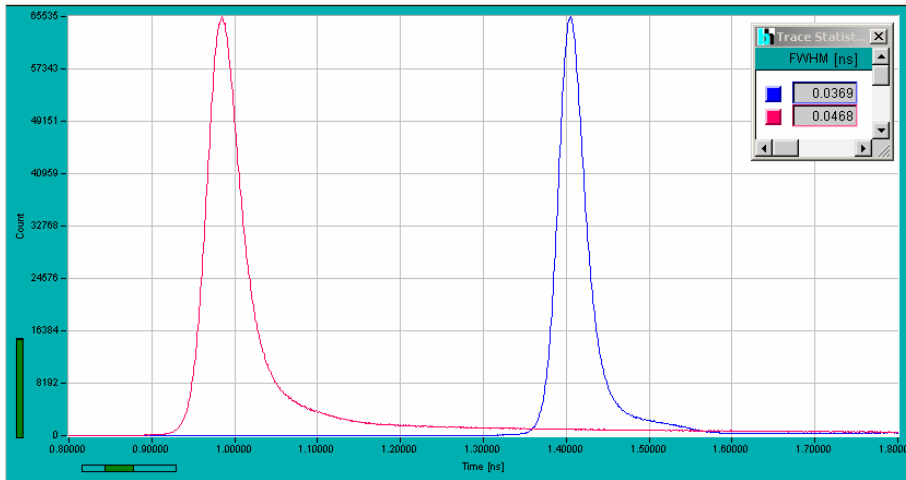

Fig. 3: Comparison of the IRF of the id100-20 (red, left) and the IRF of an R3809U MCP-PMT (blue, right). The measured FWHMs are 47 ps for the id100-20 and 37 ps for the MCP-PMT.

The true IRF width of the MCP-PMT is known to be about 28 ps. With this value, the width of the laser pulse can be estimated to be about 24 ps. The corrected IRF width of the SPAD is then 40 ps.

Fig. 4 shows measurements with the BDL-405 and BDL-475 lasers at the wavelengths of 405 nm and 468 nm.

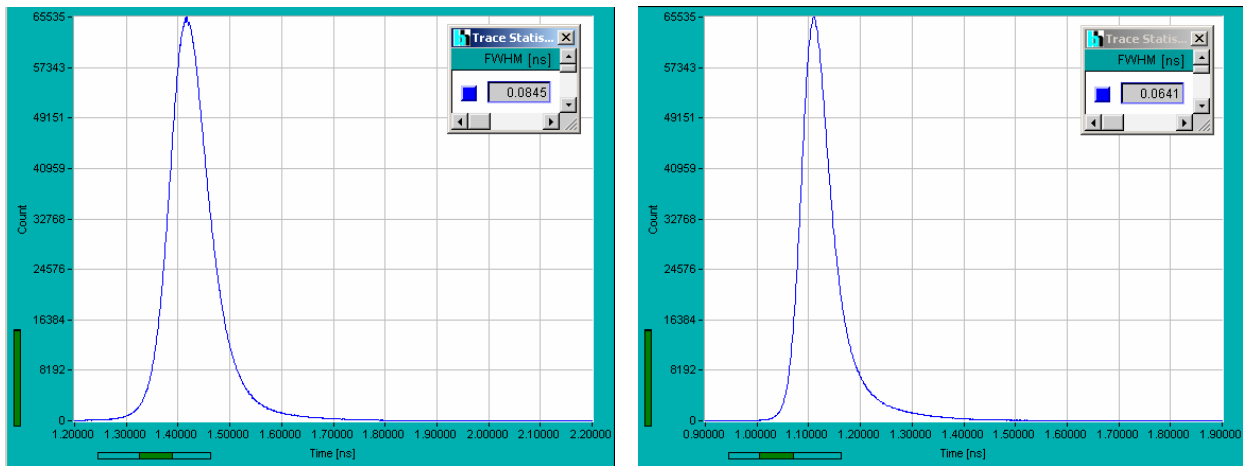

Fig. 4: Laser pulses recorded at 405 nm (left) and 468 nm (right)

The optical pulse width of these lasers is about 68 ps and 58 ps, respectively. Consequently, the recorded pulses are broader than the true IRF of the SPAD.

The comparison of the IRFs of the SPAD and the MCP PMT shows remarkable differences, see fig. 5.

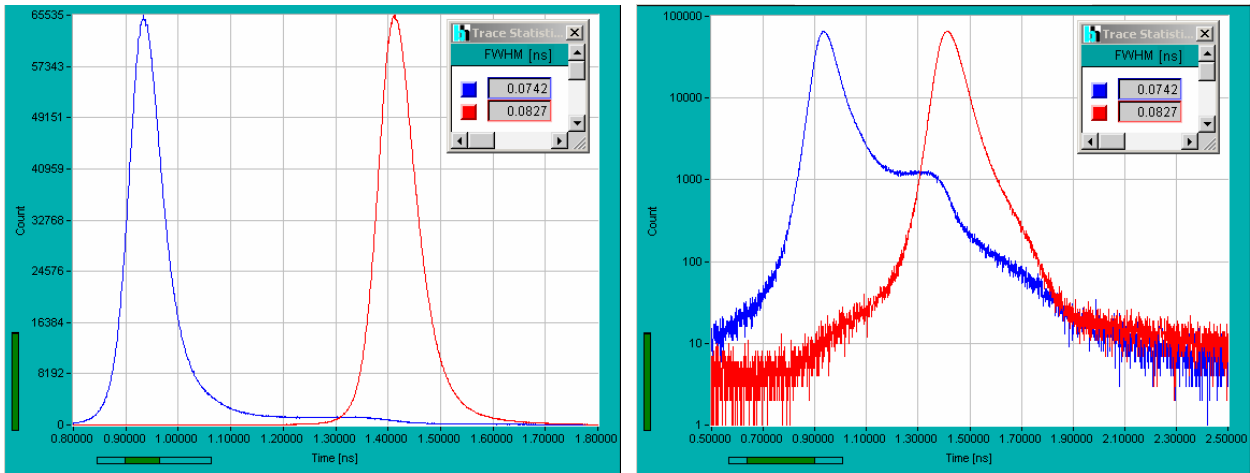

Fig. 5: Laser pulses recorded at 405 nm. Blue MCP PMT, red id100-20. Left linear scale, 100 ps / div, right logarithmic scale, 200 ps / div.

Although the SPAD records the pulse with a larger FWHM than the MCP PMT the response is cleaner and drops faster at longer times. Especially, the bump in the MCP measurement is not present in the SPAD measurement. The measurement shows indeed that the bump - which is usually attributed to the laser - is actually a feature of the MCP response.

With the known response width of the MCP of 28 ps, the true laser pulse width is about 68 ps. The same pulse is recorded with an FWHM of 82.7 ps by the SPAD. The estimated FWHM of the SPAD response is then 47 ps. However, the uncertainty of this result is large. It is therefore not sure whether or not the IRF is longer at 405 nm.

Afterpulsing

The afterpulsing of the id100-20 was checked by recording the laser signal in the time-tag (FIFO) mode of the TCSPC module. The time-tag data were used to record the autocorrelation function of the photon times. Consequently, the curve resembles the result of a fluorescence correlation (FCS) measurement. The result is shown in fig. 6. The autocorrelation function is normalised to the correlation expected for uncorrelated photon data, i.e. a correlation factor of 1 means that there is no correlation between the photons.

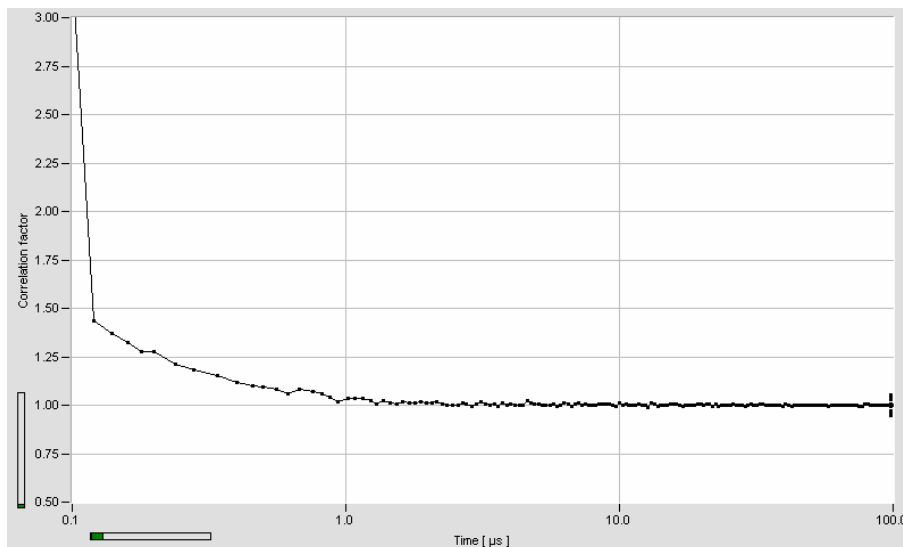

Fig. 6: Autocorrelation function of a constant laser signal, recorded at a count rate of 10 kHz.

Please note that, for a given afterpulsing probability, the amplitude of the autocorrelation curve is proportional to the reciprocal count rate.

The size and the duration of the afterpulsing is comparable to that of a good PMT. In particular, the afterpulsing ceases after about 1 μ s. Typical intersystem crossing effects and diffusion times can therefore be measured with a single detector.

Conclusions

The id100-20 of id Quantique has an extremely fast IRF and an excellent timing stability up to count rates of at least 10 MHz. The IRF is free of bumps and prepulses, and drops smoothly at longer times. The IRF at long times is in fact better than that of the Hamamatsu R3809U MCP PMT. The id100-20 is a wonderful detector for all applications in which the light can be concentrated on a small detector area. The good timing stability at high count rates then makes the id100-20 a real alternative to the R3809. Potential applications are single-molecule spectroscopy, time-resolved confocal microscopy, and experiments of quantum-key distribution. Moreover, the detector is particularly suitable for a large number of applications with relatively high light levels. It is then not necessary to focus the light perfectly on the active area. These applications include a large number of standard fluorescence lifetime experiments and laser test setups.

Wolfgang Becker
Becker & Hickl GmbH
Nahmitzer Damm 30
12277 Berlin
Tel. +49-30-787 56 32
Fax +49-30-787 57 34
becker@becker-hickl.com
<http://www.becker-hickl.com>