

# Redefining Measurement

## ID101 OEM Visible Photon Counter

Miniature Photon Counter for OEM Applications

Intended for large-volume OEM applications, the ID101 is the smallest, most reliable and most efficient single-photon detector on the market. It consists of a CMOS (Complementary Metal Oxide Semiconductor) silicon chip packaged in a standard TO5-8pin header with a transparent window cap. The chip combines either a 20  $\mu\text{m}$  (ID101-20) or a 50  $\mu\text{m}$  diameter (ID101-50) single-photon avalanche diode and a fast active quenching circuit, which guarantees a deadtime of less than 50 ns. The chip is mounted on top of a single-stage thermoelectric cooler (TEC). Three fibre-coupled versions, the ID101-SMF20, the ID101-MMF50 and the ID101-MMF100 are also available.

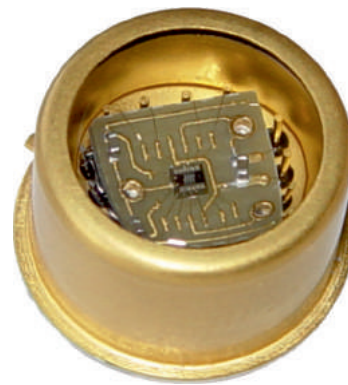

The maximum photon detection probability is measured in the blue spectral range (35% at 500 nm). An outstanding timing resolution of less than 60 ps allows high accuracy measurements. The performance of the ID101 detectors is comparable to that of the ID100-20 and ID100-50 modules. The ID101 can be mounted on a printed circuit board and integrated in apparatuses such as spectrometers or microscopes. The module is used in biological/chemical instrumentation, quantum optics, aerospace and defense applications. Contrary to legacy photomultiplier tubes (PMTs) and other silicon-based counters manufactured with non-standard custom process, the ID101 detector is fabricated using a qualified commercial CMOS process, which guarantees high reliability.

### Key Features

- ▶ Best-in-class timing resolution (40 ps)
- ▶ Low dead time (45 ns)
- ▶ Small IRF shift at high count rates
- ▶ Peak photon detection at  $\lambda = 500 \text{ nm}$
- ▶ Active area diameter of 20  $\mu\text{m}$  or 50  $\mu\text{m}$
- ▶ Free-space, singlemode or multimode fibre coupling
- ▶ Not damaged by strong illumination
- ▶ Integrated thermoelectric cooler and thermistor
- ▶ Smallest and most reliable SPD on the market
- ▶ Easy to integrate

### Applications

- ▶ Time correlated single-photon counting (TCSPC)
- ▶ Fluorescence and luminescence detection
- ▶ Single molecule detection, DNA sequencing
- ▶ Fluorescence correlation spectroscopy
- ▶ Flow cytometry, spectrophotometry
- ▶ Quantum cryptography, quantum optics
- ▶ Laser scanning microscopy
- ▶ Adaptive optics
- ▶ Particle physics
- ▶ Dynamic light scattering (DLS)

## OEM VISIBLE PHOTON COUNTER

### Specifications

Parameter	Min	Typical	Max	Units
Wavelength range	350		900	nm
Active area diameter				
ID101-20 / ID101-SMF20		20		µm
ID101-50 / ID101-MMF50 or MMF100		50		µm
Timing resolution [FWHM] <b>1</b>		40	60	ps
Single-photon detection probability (SPDE) <b>2</b> <b>1</b>				
at 400 nm	15	18		%
at 500 nm	30	35		%
at 600 nm	20	25		%
at 700 nm	15	18		%
at 800 nm	5	7		%
at 900 nm	3	4		%
Dark count rate (DCR)				
ID101-20		30	250	Hz
ID101-50		100	300	Hz
Afterpulsing probability <b>3</b>		0.5		%
Output pulse width				
ID101-20 / ID101-SMF20 <b>4a 5a</b>	30	35	40	ns
ID101-50 / ID101-MMF50 or MMF100 <b>4b 5b</b>	40	45	50	ns
Output pulse amplitude (in high impedance) <b>4a 4b</b>		VDD		V
Output driver capability		4		mA
Deadtime				
ID101-20 / ID101-SMF20	30	35	40	ns
ID101-50 / ID101-MMF50 or MMF100	40	45	50	ns
Maximum count rate (pulsed light)				
ID101-20 / ID101-SMF20 <b>6a</b>			28	MHz
ID101-50 / ID101-MMF50 or MMF100 <b>6b</b>			22	MHz
VDD supply voltage	4.8	5.0	5.2	V
Current on VDD	0.25		2.2	mA
VOP supply voltage	-24		-26	V
Current on VOP			100	µA
Storage temperature	-40		70	°C

- 1** The ID101-SMF20 comes with a singlemode fibre optimized to your operating wavelength. The overall coupling efficiency exceeds 90%.  
 The ID101-MMF50 comes with a 50/125 µm multimode fibre pigtail. The overall coupling efficiency exceeds 80%.  
 The ID101-MMF100 comes with a 100/125 µm multimode fibre pigtail. The overall coupling efficiency exceeds 50%.

### Thermoelectric Cooler Specifications

Parameter	Unit	Value (conditions)
Resistance ACR	Ω	3.56 +/- 0.16 (at T <sub>r</sub> =300 K)
Maximum Current I <sub>max</sub>	A	0.4 +/- 0.02 (at ΔT <sub>max</sub> )
Maximum Voltage Drop U <sub>max</sub>	V	1.35 +/- 0.07 (at ΔT <sub>max</sub> )
Maximum Delta-T ΔT <sub>max</sub>	K	67.0 +/- 2.0 (Vacuum, Q=0, T <sub>r</sub> =300 K)
Maximum Cooling Capacity Q <sub>max</sub>	W	0.29 +/- 0.01 (at ΔT=0)

**Disclaimer** - The information and specification set forth in this document are subject to change at any time by ID Quantique without prior notice. Copyright© 2017 ID Quantique SA - All rights reserved -ID101 v2017 05 01 - Specifications as of May 2017

### 1 Timing Resolution

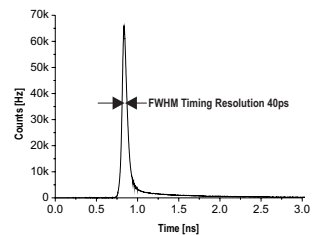

### 2 Photon Detection Probability versus λ

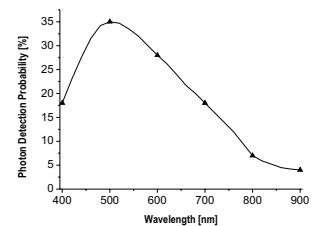

### 3 Afterpulsing

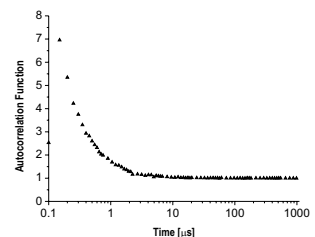

Typical autocorrelation function of a constant laser signal, recorded at a count rate of 10 kHz.

### Thermosensor Specifications

Parameter	Unit	Value (conditions)
Resistance R0	kΩ	2.2 +/- 0.16 at 293 K
Beta Constant β	K <sup>-1</sup>	2918.9 +/- 5%

The thermistor resistance can be calculated by:  
 $RT = R_{293K} \cdot \exp(b(293-T)/(293 \cdot T))$

### Mounting Details

TEC mounting	soldering, 117°C
Thermosensor mounting	epoxy glue
Wire mounting	soldering, 183°C

## OEM VISIBLE PHOTON COUNTER

### Principle of Operation

The ID101 is based on a 0.8x0.8 mm<sup>2</sup> CMOS silicon chip containing a 20 μm or 50 μm diameter avalanche diode and its active quenching circuit. To operate in the Geiger mode, the diode anode is biased with a negative voltage  $V_{op}$ . The cathode is linked to VDD through a polysilicon resistor  $R_q$ . Before the photon arrival, the switch is open (non-conducting) and the cathode is at VDD. When a photon strikes the diode, the voltage drop induced on the cathode is sensed by the sensing circuit. The output pin OUT switches to VDD. The feedback circuit closes the switch: the diode is biased below its breakdown voltage resulting in the avalanche quenching. The diode is then kept below breakdown and the recharge takes place with the opening of the switch. The full cycle is defined as the sensor dead time. In any single-photon avalanche diode, thermally generated carriers induce false counts, called dark counts. A single-stage thermoelectric cooler (TEC) allows to cool the device to reduce the dark count rate. Furthermore, the photon detection probability in a single-photon avalanche diode is dependent on the excess bias voltage above breakdown. The breakdown voltage being temperature dependent, it is often crucial to keep the sensor at a constant temperature. The thermistor included in the ID101 allows one to implement a temperature control circuit.

### Block Diagram

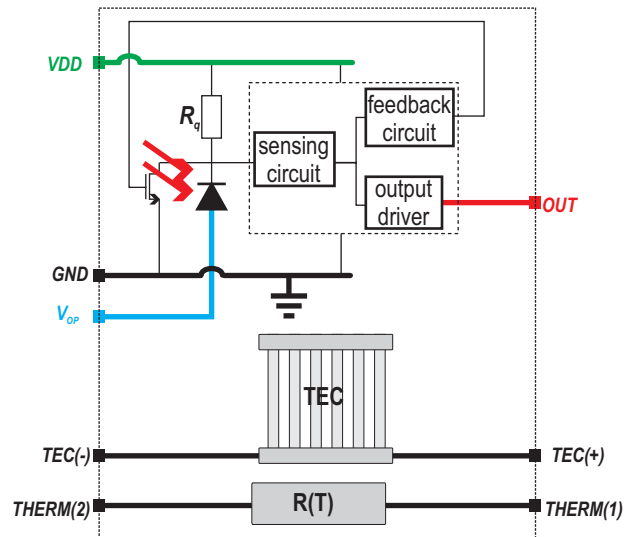

### Dimensional Outline (in mm) and Pinout

#### ID101-MMF50 fiber-coupled version

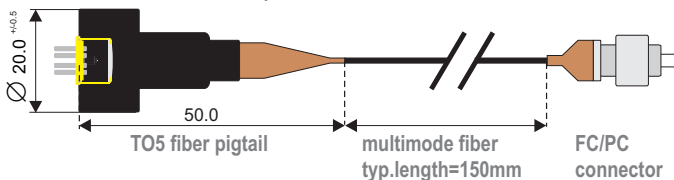

- Window material: glass
- Pin material: gold plated
- The 20 μm or 50 μm active area is aligned with the centre of the glass window. The positioning accuracy is +/- 100 microns.

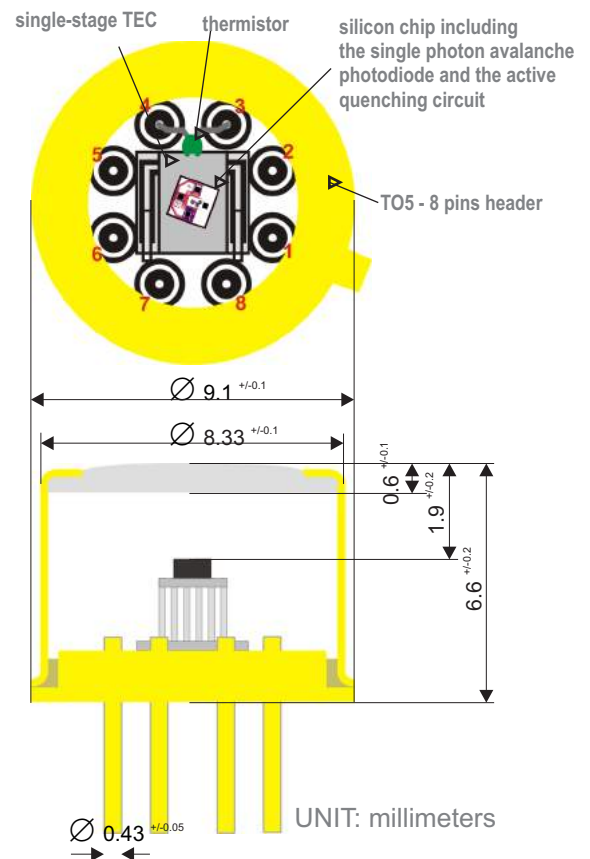

pin #	connexion
1	$V_{OP}$
2	VDD
3	thermistor
4	thermistor

pin #	connexion
5	GND
6	OUT
7	TEC(-)
8	TEC(+)

## OEM VISIBLE PHOTON COUNTER

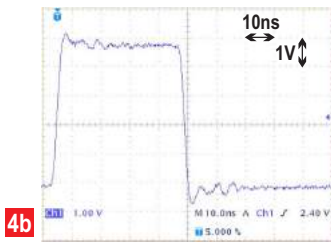
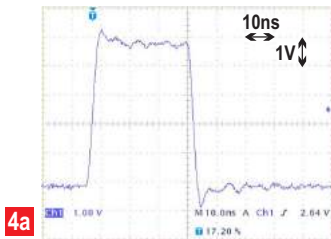

Typical pulses observed at the ID101-20 or ID101-SMF20 (4a) and ID101-50 or ID101-MMF50 or ID101-MMF100 (4b) outputs in high impedance.

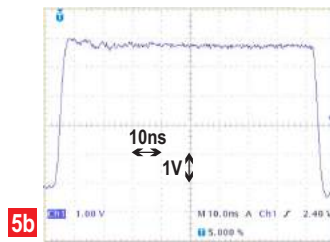
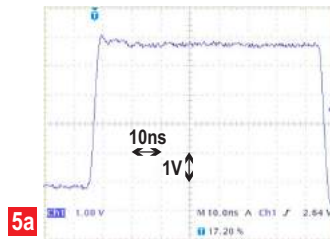

Extended pulses observed at the ID101-20 or ID101-SMF20 (5a) and ID101-50 or ID101-MMF50 or ID101-MMF100(5b) outputs at high illumination level. When an avalanche is triggered during the recharge process, the output remains high, giving an extended pulse. This effect leads to a decrease of the output count rate.

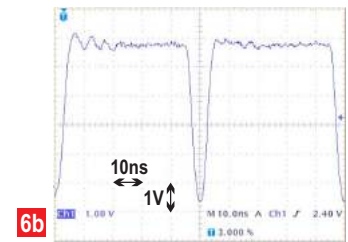
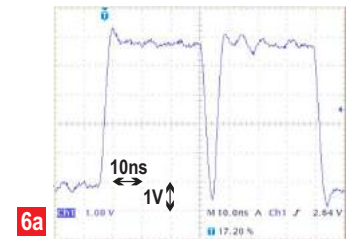

The short dead time of the ID101 allows operation at very high repetition frequencies, up to 28 MHz for the ID101-20 or ID101-SMF20 (6a) and 22 MHz for the ID101-50 or ID101-MMF50 or ID101-MMF100 (6b).

## ID101 - EVA Evaluation Board

An evaluation board has been developed for preliminary optical and electrical testing of the ID101. The ID101 under test can be plugged into a socket intended for TO5 headers. The evaluation board comes with a power supply with universal range of input plugs and a 1 m coaxial cable ended with a BNC connector.

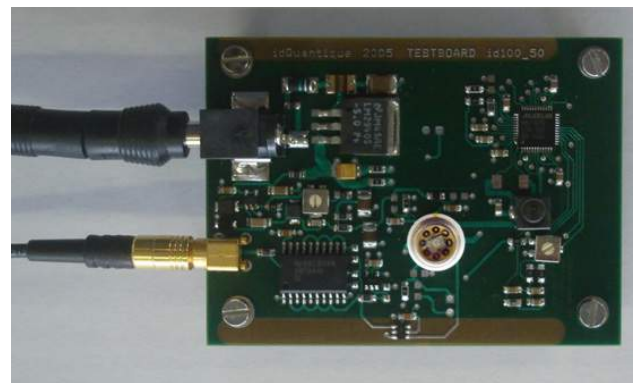

## Application Example - Combination in Array

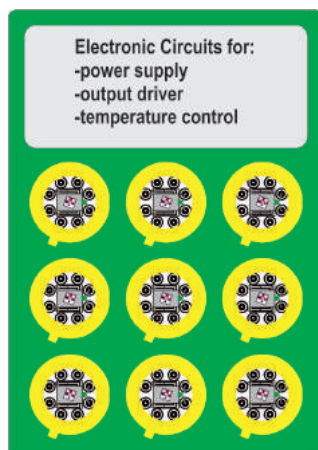

Many industrial applications would greatly benefit from a single-photon detector array. When the required array size is reasonably small (i.e.  $< 10 \times 10$ ), it is possible to assemble several closely spaced TO5 headers to form an array. As illustrated in the figure, opposite, for a  $3 \times 3$  array, several TO headers can be mounted on a printed circuit board. The minimum center-to-center pitch is 9.5 mm. Common electronic circuits for power supply, output stage and temperature control can be implemented on the PCB. If a high accuracy for the distance from pixel to pixel is required or if a large array is needed, IDQ offers a custom design service for the design of an application-specific CMOS chip.

## OEM VISIBLE PHOTON COUNTER

### Typical Application Circuit

#### ► Power Stage

The ID101 requires two power supplies, VDD and VOP. A standard inverting DC/DC converter can convert the +5V level to the high negative voltage level VOP. The remaining electronic circuits on the PCB board can be supplied with the same +5 V power. Two 100 nF capacitances must be added as close as possible to the output pins for decoupling purpose.

#### ► Output Stage

The ID101 output can be shaped for the back-end electronic circuits (e.g. counter, TDC, TAC) using the circuit shown below. A D-type Flip-Flop with asynchronous clear combined with a delay generator (RC for instance) and an inverter with a Schmitt trigger input allows to set the pulse width and the dead time.

#### ► Temperature Control

For proper operation, it is highly recommended to implement a thermal stabilisation circuit on the final printed circuit board, using the single-stage TEC and the 2.2 kΩ thermistor provided. Integrated temperature controllers for Peltier modules are commercially available.

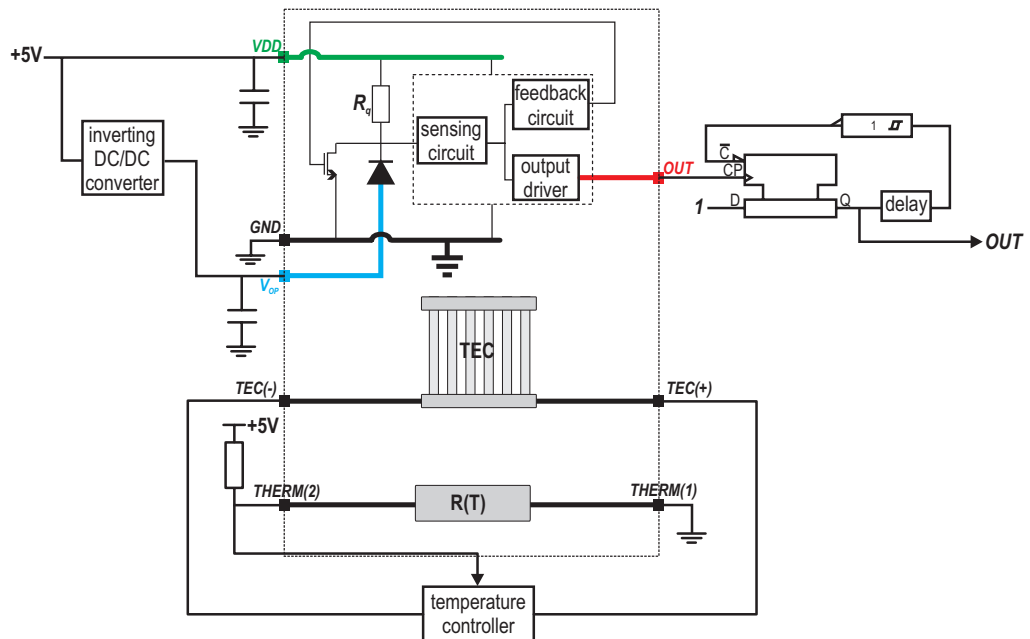

### Accessory - Optional Pulse Shaper

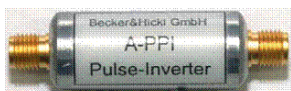

IDQ provides as an option a pulse shaper (A-PPI-D) which can be used with devices requiring negative input pulses. The leading edge of the ID101 output pulse is converted into a sharp negative pulse with typical amplitudes of 1.4 V for a 50 Ω load and 2.5 V for a high impedance load. The pulse shaper comes with two SMA/BNC adapters.

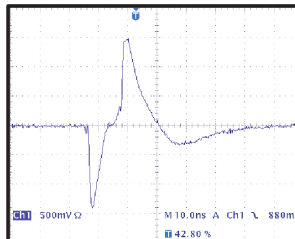

Typical output pulse of an ID101 equipped with a A-PPI-D pulse shaper in 50 Ω load.

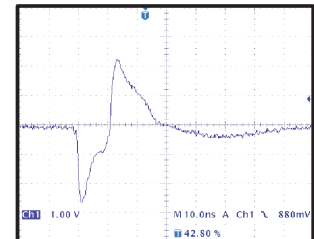

Typical output pulse of an ID101 equipped with a A-PPI-D pulse shaper in high impedance load.